

ASSEMBLY AND INSTRUCTION MANUAL (EN)

mill®

Series: Steel & Glass WiFi (Convector heater)

Please read the instructions carefully before use.

Take good care of this manual for later use.

INFORMATION HOTLINE; If you have any questions or comments after reading this owner's guide, please feel free to contact our customer service representative by email at us.support@millheat.com or by phone 1-855-875-0698. Our customer service representative will be happy to help you.

This assembly and instruction manual applies to the following products:

Mill Steel WiFi: NE600WIFI, NE1200WIFI, NE800LWIFI

Mill Glass WiFi: AV600WIFI, AV1200WIFI, AV800LWIFI



Important safety information

Thank you for choosing this Mill heater. To ensure the best performance from your heater, please read and save the following important instructions. You must obey common safety guidelines when using electrical products, especially in the presence of children.

IMPORTANT INSTRUCTIONS

WHEN USING ELECTRICAL APPLIANCES, BASIC PRECAUTION SHOULD ALWAYS BE FOLLOWED TO REDUCE THE RISK OF FIRE, ELECTRIC SHOCK AND INJURY TO PERSON, INCLUDING THE FOLLOWING:

1. Read all instructions before using this heater.
2. This heater is hot when in use. To avoid burns, do not let bare skin touch hot surfaces. If provided, use handles when moving this heater. Keep combustible materials, such as furniture, pillows, bedding, papers, clothes, and curtains at least 0.9m from the front of the heater and keep them away from the sides and rear.
3. Extreme caution is necessary when any heater is used by or near children or disabled people and whenever the heater is left operating and unattended.
4. Always unplug heater when not in use.
5. Do not operate any heater with a damaged cord or plug or after the heater malfunctions, has been dropped or damaged in any manner. Discard heater, or return to authorized service facility for examination and/or repair.
6. Do not use outdoors.
7. This heater is not intended for use in bathrooms, laundry areas and similar indoor locations. Never locate heater where it may fall into a bathtub or other water container.
8. Do not run cord under carpeting. Do not cover cord with throw rugs, runners, or similar coverings. Do not route cord under furniture or appliances. Arrange cord away from traffic area and where it will not be tripped over.
9. To disconnect heater, turn controls to off, then remove plug from outlet.
10. Do not insert or allow foreign objects to enter any ventilation or exhaust opening as this may cause an electric shock or fire, or damage the heater.
11. To prevent a possible fire, do not block air intakes or exhaust in any manner. Do not use on soft surfaces, like a bed, where openings may become blocked.
12. A heater has hot and arcing or sparking parts inside. Do not use it in areas where gasoline, paint, or flammable liquids are used or stored.
13. Use this heater only as described in this manual. Any other use not recommended by the manufacturer may cause fire, electric shock, or injury to persons.
14. Always plug heaters directly into a wall outlet/receptacle. Never use with an extension cord or relocatable power tap (outlet/power strip).
15. This appliance is not intended for use by persons (including children) with reduced physical, sensory or mental capabilities, or lack of experience and knowledge, unless they have been given supervision or instruction concerning use of the appliance by a person responsible for their safety.

16. Children should be supervised to ensure that they do not play with the appliance.
17. If the SUPPLY CORD is damaged, it must be replaced by the manufacturer, its service agent or similarly qualified person in order to avoid a hazard.
18. The meaning of figure  in marking is "DO NOT COVER".
19. WARNING: In order to avoid overheating, do not cover the heater.
20. The instructions shall state that the heater must not be located immediately below a socket outlet.
21. Do not use this heater in the immediate surroundings of a bath, a shower or a swimming pool.
22. Pay special attention if the heater is used in rooms where children, the handicapped or elderly reside, and whenever the heater is left operating unattended.
23. Extreme caution is necessary when the heater is used by or near children or disabled people and whenever the heater is left operating and unattended.
24. The device cannot be used by children under 8 years of age and persons with reduced physical or mental abilities or lack of experience and knowledge unless they have been given supervision or instruction in the safe use of the device and understand the hazards involved.
25. Children should not play with the device. Cleaning and maintenance should not be done by unsupervised children.
26. Children under the age of 3 should be kept away from the device, unless they are under constant supervision.
27. Children aged 3 to 8 years are only permitted to turn the device ON/OFF, assuming the device is mounted according to the assembly instructions and the children have received instruction or supervision in the safe use of the device and understand the hazards involved.
28. If the heater will not operate please contact the store where you bought the heater or our customer service representative at 1-855-875-0698 or email us.support@millheat.com.
29. Do not disassemble the heater.

SAVE THESE INSTRUCTIONS

Safety features

AUTOMATIC OVERHEATING PROTECTION

To avoid damage and danger by overheating, the heater is equipped with a protection switch that turns the unit off if it overheats.

Cleaning/maintenance instructions;

During season care

- 1) Before cleaning, always turn off and unplug the heater, and leave it to cool.
- 2) Wipe the heater regularly with a soft, damp cloth and dry the surface before turning on the heater again.
- 3) Do not immerse the heater in water.
- 4) Never use detergents, gasoline, benzene or thinner to clean the heater. This will damage its surface.
- 5) The heater must be cleaned at least once a month during the heating season.

Caution! Never let any water get inside the heater; this can be hazardous.

- 6) Dust etc. should be removed with a soft cloth.
- 7) After cleaning, be sure to dry the heater with a cloth or towel.
- 8) Store the heater in a dry and clean place.
- 9) If the heater stops working, do not attempt to repair it yourself because it can cause a fire hazard and/or electric shock.

After season care.

- 1) Store heater in a cool and dry location with the power cord properly secured.
- 2) Please store the unit in its original carton or a suitable container.

PRE-OPERATING INSTRUCTIONS:

- 1) Carefully remove the heater from the box (please save the carton for off-season storage), and remove the plastic bag before use. Keep the plastic bag away from children.
- 2) After unpacking the heater, check to make sure that the product was not damaged during transport. Contact the retailer or importer if you discover any visible damages to the product.
- 3) Attach the heater to the wall according to instructions, before plugging the heater into the outlet.
- 4) Keep the outer packaging to transport the heater in the future. If you want to dispose of the packaging, make sure it is done properly.

STORE THIS INSTRUCTION MANUAL FOR FUTURE USE!

NEVER TOUCH YOUR HEATER OR ITS CASING WITH WET HANDS!

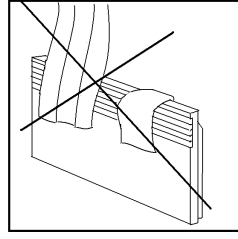
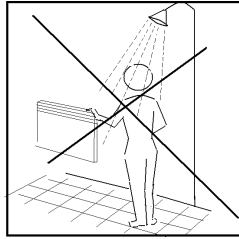

Specifications

Model	Thermostat	Color	Height	Width	Amperage	Power (W)	IP rating	WiFi
NE600WIFI	WiFi	White	15,7 inches	25,6 inches	~120V/60Hz	600	IPx4	802.11b/g/n
NE1200WIFI	WiFi	White	15,7 inches	41,3 inches	~120V/60Hz	1200	IPx4	802.11b/g/n
NE800LWIFI	WiFi	White	9,8 inches	41,3 inches	~120V/60Hz	800	IPx4	802.11b/g/n
AV600WIFI	WiFi	White	15,7 inches	26,2 inches	~120V/60Hz	600	IPx4	802.11b/g/n
AV1200WIFI	WiFi	White	15,7 inches	41,9 inches	~120V/60Hz	1200	IPx4	802.11b/g/n
AV800LWIFI	WiFi	White	9,8 inches	41,9 inches	~120V/60Hz	800	IPx4	802.11b/g/n

First use

After turning on the heater for the first time or after an extended period without use, the heater can produce a burnt odor for a short time. This is normal.

Please read all the instructions carefully before use. Save the instruction manual for future use.

It is also normal for the heater to make sounds when it warms up or cools down.



DO NOT COVER

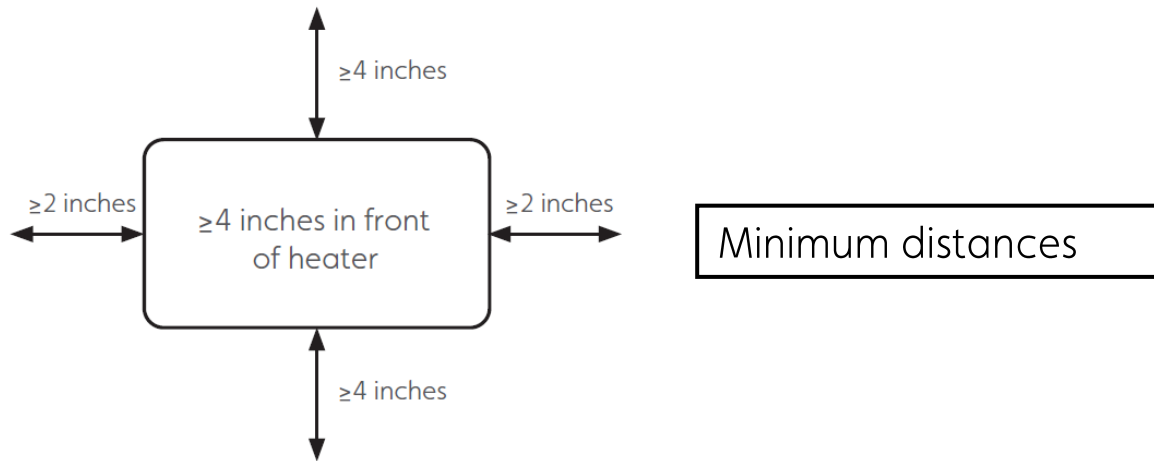

Description of heater

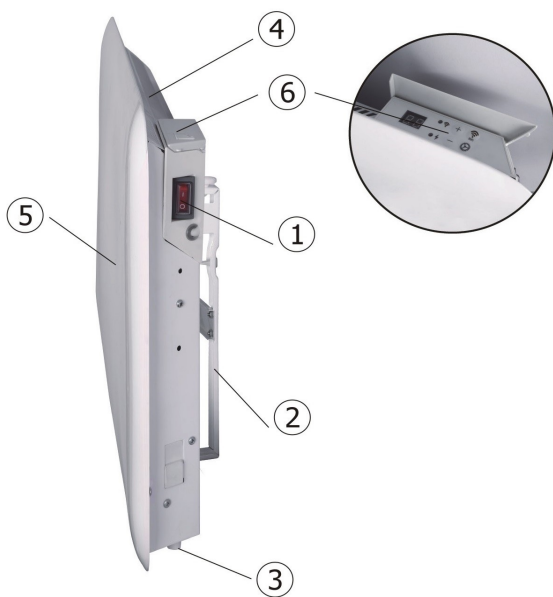

Mill Steel WiFi

1. Off/On
2. Wall bracket
3. Temperature sensor
4. Heat emission
5. Steel front
6. Thermostat WiFi

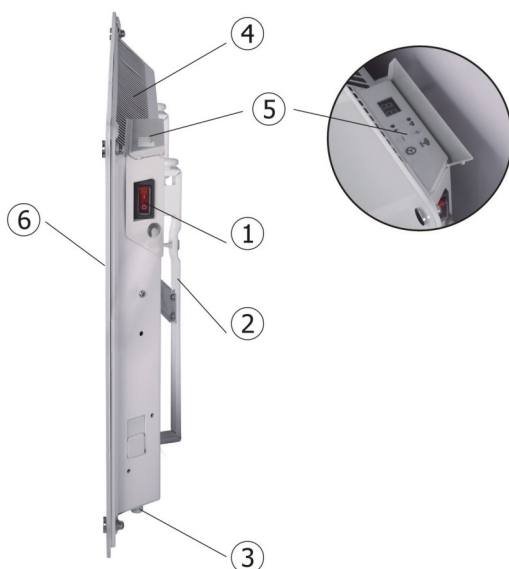

Mill Glass WiFi

1. Off/On
2. Wall bracket
3. Temperature sensor
4. Heat emission
5. Thermostat WiFi
6. Glass front

Assembly

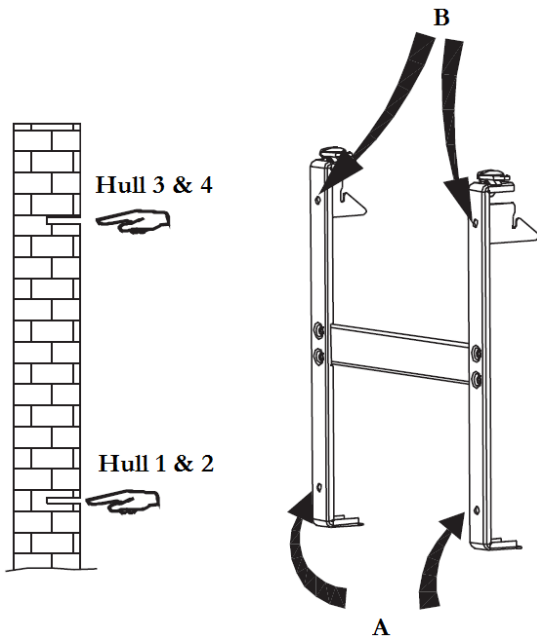

Use a tape measure and a spirit level to mount the bracket

1. Drill holes in the wall for holes 1 & 2. Then drill holes in the wall for the topmost holes (holes 3 & 4 by using B)

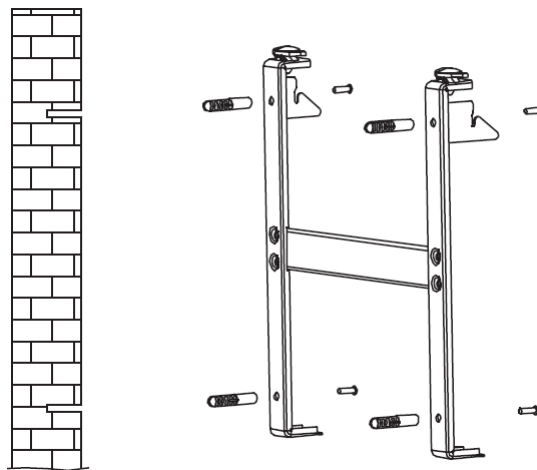

2. Insert the wall plugs into the drilled holes and attach the bracket with 4 screws

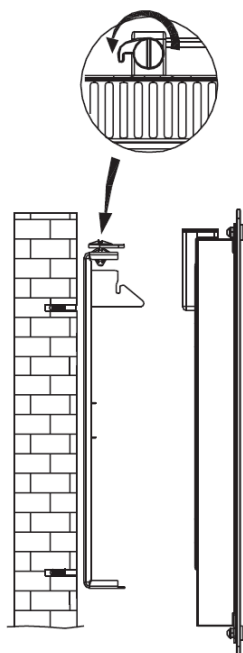

3. Place the heater on the lower lugs on the bracket, then hang the heater on the upper lugs (lift the heater slightly to align the heater with for the upper lugs). Screw in the locking screws on the top of the bracket (clockwise)

WiFithermostat - instructions

CAUTION! In the event of a power cut, the thermostat will reconnect with WiFi where all the temperatures are saved.

Relevant for the following models:

NE600WIFI NE1200WIFI NE800LWIFI



AV600WIFI, AV1200WIFI, AV800LWIFI

Tip! The thermostat can be used as a normal electronic thermostat (meaning the heater will keep an even temperature the whole day and night). See point 1 on page 9.

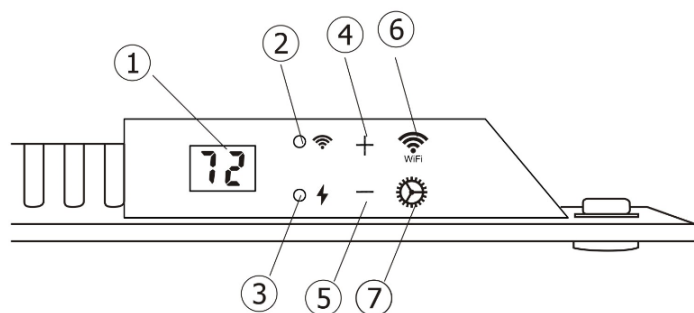
Control panel for WiFi-thermostat:



1. Display (shows the desired room temperature by default)
2. Control light WiFi
3. Power indicator — Shows whether the heater is using power or not
4. Control button (+) (increase temperature)
5. Control button (-) (reduce temperature)
6. WiFi button
7. Function button (F)

Attention! The thermostat on the heater shows degrees in «Fahrenheit» by default. If you wish to change from «Fahrenheit» to «Celsius» please press  and hold for 3 seconds. To change back to «Fahrenheit» please press  again and hold for 3 seconds.

Warning: Before the heater is turned on, it must be attached to a wall. If the heater is not installed correctly or is installed askew, this may cause the heater to malfunction or in the worst case, be damaged.

If the temperature sensor is not functioning properly, you will see the symbol below on the display. Please contact the dealer or importer.



Usage without WiFi connection

1) Set the desired temperature

Press the +/- buttons to set the desired temperature. The heater keeps an even temperature the whole day and night.

Attention! Can only be done when WiFi is deactivated (see point 2 on page 12 for deactivating WiFi).

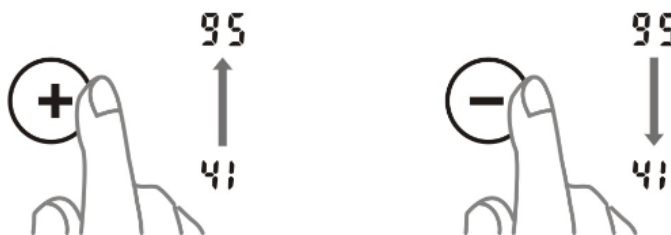

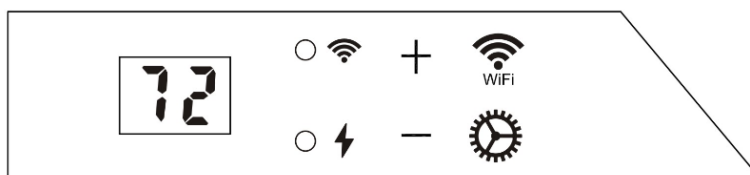

2) Power indicator

When the panel heater is using power (i.e. when it is heating), the power indicator is lit.



3) Temperature calibration

*Should any deviations occur between the desired and actual temperature in the room, it can be easily adjusted (the heater should have been set to the same setting for at least 12 hours in order to be sure a calibration is necessary).

Press  2 times, and use +/- to set the actual temperature observed in the room. Confirm by pressing  or wait 15 seconds for automatic confirmation.

(Can be done even if you are connected to WiFi).

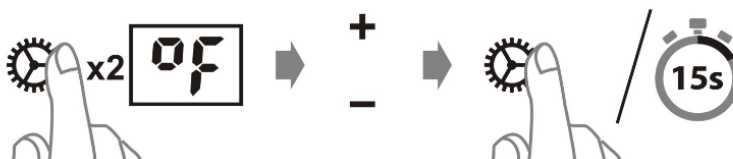

4) Resetting the heater

Turn off the heater's main switch. Press and hold  while you turn on the heater's main switch.

5) Memory function

The heater remembers all the temperature settings and will automatically return to the desired temperature after a power failure.

6) «Open window» function

The heater has an «open window» function that is activated instantly when it registers a sudden drop in temperature with more than 35,6 degrees Fahrenheit in 2 minutes. The heater will automatically stop heating and FO will be visible in the display of the heater.

The heater will automatically start heating again after 10 minutes (the display switch from FO to desired room temperature).

Usage with WiFi

A free app is available for downloading for iOS and Android.

By connection your heaters with the iOS/Android device you can do the following:

- Control all your heaters situated in multiple locations . Everything is controlled with the Millheat-app (with same user)
- Set up weekly programs (or use the standard program already available in the app) by using the 3 modes: Comfort, Sleep, Away
- Set individual temperature for 3 different modes in each room
- Override the set programs for the whole house, a specific room or a specific heater. There is no need to edit your program if you get home earlier than normal one day
- Enable vacation mode for saving energy while you are away. The app will automatically increase the temperature in your house before you get back home
- Share your house with other family members, making control easy
- If internet is down one can easily turn off the WiFi on the heaters and control them manually, so that the heaters keep an even temperature throughout the whole day and night. See usage without WiFi on page 9
- + many other things

To download the app search for «millheat» in Appstore or Google Play and install the app on your device.

Before use:

Be aware that the Millheat-app must be installed before you can connect your heaters to your WiFi network. You can then simply follow the instructions given in the app when connecting your heaters.

Go to our help desk at www.millheat.com for more information or if you have any questions regarding the Millheat-app, connecting to WiFi or other relating questions.

Attention! The heaters will be connected directly to your WiFi router and it is therefore important to make sure the router has sufficient capacity for the amount of active devices connected at the same time.

Usage with WiFi continues

Power indicator

When the panel heater is using power (i.e. when it is heating), the power indicator is lit.

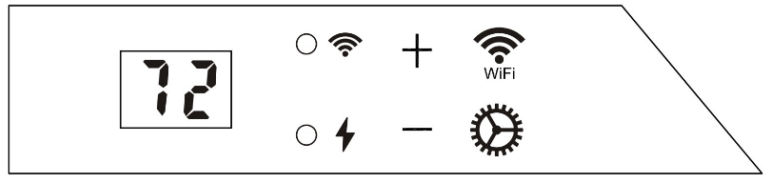

Color codes (WiFi control light)



The heater has not been connected to WiFi. The heater keeps an even temperature throughout the whole day and night. See page 9



The heater is online in the Millheat cloud



(flash)

- 1) The heater's WiFi is deactivated by the user
- 2) When installing/connecting the Millheat-app and cloud, the light will flash in various speed. This is normal.



(flash)

- The heater has a problem connecting to or finding the WiFi signal. Please do the following:
- 1) Please turn the heater OFF and ON again.
 - 2) Please restart the WiFi router
 - 3) Please check the WiFi router to make sure the capacity is sufficient for the amount of active devices connected at the same time



The heaters are offline and have no contact with the Millheat cloud

«Open window» function

The heater has an «open window» function that is activated instantly when it registers a sudden drop in temperature with more than 35,6 degrees Fahrenheit in 2 minutes. The heater will automatically stop heating and FO will be visible in the display of the heater.

The heater will automatically start heating again after 10 minutes (the display switch from FO to desired room temperature).

Usage with WiFi continues

1) Activating WiFi

Press «add heater» on the home screen in the Millheat-app. Follow the instructions in the app.



2) Deactivating WiFi

Press 1 time on the WiFi button. The heater can now be used as described on page 9 (without WiFi). Relevant only if WiFi is already installed.



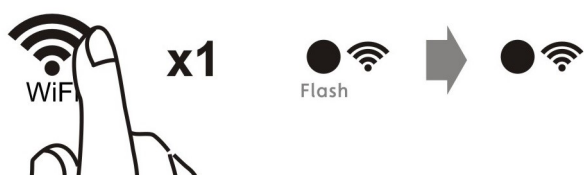

3) Reconnecting WiFi

Press the WiFi button 1 time. Relevant only if WiFi is already installed.



4) Temperature calibration

*Should any deviations occur between the desired and actual temperature in the room, it can be easily adjusted (the heater should have been set to the same setting for at least 12 hours in order to be sure a calibration is necessary).

Press  2 times, and use +/- to set the actual temperature observed in the room. Confirm by pressing  or wait 15 seconds for automatic confirmation.

(Can be done even if you are connected to WiFi).

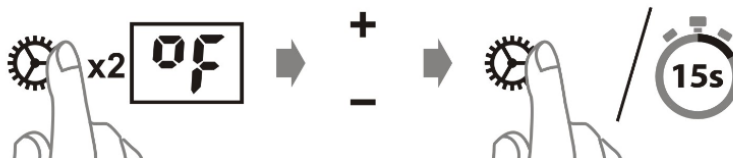

5) Delete WiFi settings

Delete WiFi-settings: Press and hold WiFi button for 3 seconds.

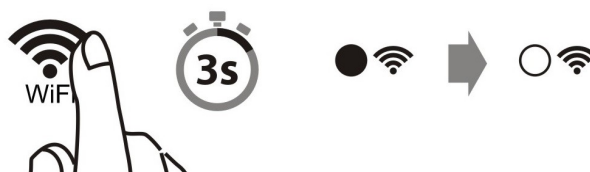

The heater can also be reset to the factory settings by doing the following: Turn off the heater's main switch. Press and hold  while you switch on the heater's main switch.

6) Memory function

When the heater is connected to WiFi it will automatically reconnect to WiFi (where all temperatures are saved) after a power failure.

Warranty

For your own records, staple or attach your sales receipt to this manual. Please also write the store name/location and date purchased below.

STORE NAME/LOCATION: _____

DATE PURCHASED: _____

Please save this warranty information.

The warranty is valid for 2 years. The heater will be replaced during this time should any malfunction occur. The warranty applies if the heater is used according to these instructions, the customer can present a purchase receipt and as long as this product is only used for private household purposes. If the heater malfunctions in any way, please contact the store where it was purchased or the importer.

Mill International B.V. warrants to its customers and/or consumer of this electric heater and the parts thereof will be free from defect in material and workmanship, under normal use, for a period of two (2) years from the date of initial purchase. The warranty does not apply to repairs necessitated by damage, misuse, abuse or alternation and to any repair of merchandise not used within the United States or Canada. Unless otherwise prescribed by law, Mill International B.V. shall not be liable for any personal injury, property damage or any incidental or consequential damages of any kind (include water damage) resulting from malfunctions, defects, misuse, improper installation or alternation of this product. This warranty is the only warranty extended by Mill International B.V. to its original customers and/or consumer having purchased this heater. Mill International B.V. disclaims all other warranties, express or implied, that arise by the operation of law, specifically including the implied warranties of merchantability and fitness for a particular purpose. Mill International B.V. shall not be liable for any incidental or consequential damage, which may have resulted from any alleged breach of warranty. Some states do not allow limitations on how long implied warranty lasts or the exclusion or limitation of incidental or consequential damage, so the above limitations or exclusion may not apply to you. This warranty gives you specific legal rights. You may also have other rights which vary from state to state.

Should the heater fail during the warranty period, the owner should:

Within the first 30 days from date of purchase, the store from which you purchased your Mill product should replace this product if it is defective in material or workmanship (provided the store has in-stock replacement).

Within the 24 months from date of purchase (i.e. the warranty period), Mill International B.V. will replace the product if it is defective in material or workmanship providing it is returned to the store where it was purchased, with evidence of purchase date (registered receipt).

IMPORTANT: DO NOT ATTEMPT TO REPAIR THIS HEATER YOURSELF. DOING SO MAY VOID YOUR WARRANTY. PLEASE RETAIN THIS WARRANTY AND YOUR SALES RECEIPT TO INSURE YOUR PRODUCT WARRANTY.

Caution:

Any changes or modifications not expressly approved by the party responsible for compliance could void the user's authority to operate the equipment.

This equipment has been tested and found to comply with the limits for a Class B digital device, pursuant to part 15 of the FCC Rules. These limits are designed to provide reasonable protection against harmful interference in a residential installation. This equipment generates uses and can radiate radio frequency energy and, if not installed and used in accordance with the instructions, may cause harmful interference to radio communications. However, there is no guarantee that interference will not occur in a particular installation. If this equipment does cause harmful interference to radio or television reception, which can be determined by turning the equipment off and on, the user is encouraged to try to correct the interference by one or more of the following measures:

- Reorient or relocate the receiving antenna.
- Increase the separation between the equipment and receiver.
- Connect the equipment into an outlet on a circuit different from that to which the receiver is connected.
- Consult the dealer or an experienced radio/TV technician for help.

MPE Reminding

To satisfy FCC RF exposure requirements, a separation distance of 7.9 inches (20 cm) or more should be maintained between the antenna of this device and persons during device operation.

To ensure compliance, operations at closer than this distance is not recommended.

This device complies with part 15 of the FCC Rules. Operation is subject to the following two conditions: (1) This device may not cause harmful interference, and (2) this device must accept any interference received, including interference that may cause undesired operation.

Service instructions:

Do NOT attempt to repair or adjust any electrical or mechanical functions on the heater. Doing so will void the warranty.

If you have any questions regarding this heater's operation or any other questions or comments, please call 1-855-875-0698 to speak with a customer service representative or send an e-mail to us.support@millheat.com.

If you need to exchange the unit, please return it, in its original carton with a sales receipt enclosed, to the store you purchased it. If you are returning the unit more than 30 days after the date of purchase, please see the enclosed warranty.

IMPORTANT: Return instructions:

Your warranty depends on you following these instructions if you are returning the unit more than 30 days after the date of purchase:

Carefully pack the heater in the original container or a suitable container to avoid damage in shipping.

Seal the carton, and then return it to the store where the heater initially was bought, please include an envelope to the store where you enclose your name, full address with zip code, daytime phone number, evidence of purchase date (register receipt). Please also include a brief explanation of the problem you are having with the unit.

Mill International B.V. recommends you insure the package (as damage in shipping is not covered by your warranty).

All shipping charges must be prepaid by you (as noted as above).

Waste disposal

The symbol  indicates that this product is not to be disposed of together with household waste. This product must be delivered to a recycling service or container for electrical appliances and electronic equipment. This is done to avoid health risks and prevent harm to the environment. Local businesses (or the environmental station in your neighborhood) are required by law to accept and recycle such products, as a means of environmentally sound disposal.

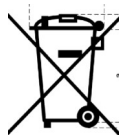

Mill International B.V.

www.millheat.com

mill®